



US009655928B2

(12) **United States Patent  
Temple**

(10) **Patent No.:** **US 9,655,928 B2**

(45) **Date of Patent:** **\*May 23, 2017**

(54) **SPINAL DISC REGENERATIVE  
COMPOSITION AND METHOD OF  
MANUFACTURE AND USE**

*27/3658* (2013.01); *A61L 27/54* (2013.01);  
*A61B 2017/564* (2013.01); *A61K 9/0019*  
(2013.01); *A61K 9/19* (2013.01); *A61L*  
*2300/418* (2013.01); *A61L 2400/06* (2013.01)

(71) Applicant: **Vivex Biomedical, Inc.**, Atlanta, GA  
(US)

(58) **Field of Classification Search**

None

See application file for complete search history.

(72) Inventor: **Harry Thomas Temple**, Miami, FL  
(US)

(73) Assignee: **Vivex Biomedical, Inc.**, Atlanta, GA  
(US)

(56) **References Cited**

U.S. PATENT DOCUMENTS

(\*) Notice: Subject to any disclaimer, the term of this  
patent is extended or adjusted under 35  
U.S.C. 154(b) by 0 days.

This patent is subject to a terminal dis-  
claimer.

7,713,303 B2 *	5/2010	Trieu et al. ....	623/17.16
8,629,122 B2	1/2014	Takahashi et al.	
2003/0069639 A1	4/2003	Sander et al.	
2007/0003525 A1 *	1/2007	Moehlenbruck .....	A61K 35/30 424/93.7
2008/0014179 A1	1/2008	Ferree et al.	
2013/0078222 A1	3/2013	Sakai et al.	

(21) Appl. No.: **14/697,778**

(22) Filed: **Apr. 28, 2015**

(65) **Prior Publication Data**

US 2016/0015754 A1 Jan. 21, 2016

**Related U.S. Application Data**

(62) Division of application No. 14/334,318, filed on Jul.  
17, 2014.

(51) **Int. Cl.**

<i>A61K 35/32</i>	(2015.01)
<i>A61L 27/36</i>	(2006.01)
<i>A61L 27/38</i>	(2006.01)
<i>A61L 27/58</i>	(2006.01)
<i>A61F 2/44</i>	(2006.01)
<i>A61B 17/88</i>	(2006.01)
<i>A61K 45/06</i>	(2006.01)
<i>A61L 24/00</i>	(2006.01)
<i>A61L 24/10</i>	(2006.01)
<i>A61L 27/54</i>	(2006.01)
<i>A61B 17/70</i>	(2006.01)
<i>A61K 9/00</i>	(2006.01)
<i>A61K 9/19</i>	(2006.01)
<i>A61B 17/56</i>	(2006.01)

(52) **U.S. Cl.**

CPC ..... *A61K 35/32* (2013.01); *A61B 17/7061*  
(2013.01); *A61B 17/8805* (2013.01); *A61K*  
*9/0085* (2013.01); *A61K 45/06* (2013.01);  
*A61L 24/0015* (2013.01); *A61L 24/106*  
(2013.01); *A61L 27/3612* (2013.01); *A61L*

OTHER PUBLICATIONS

“The Intervertebral Disc” Shapiro, Risbud (Eds), Springer-Verlag  
Wien, New York, Sep. 2013. pp. 418-420.\*

Sigma-Aldrich “Syringe Needle Gauge Chart” retrieved from inter-  
net <[http://www.sigmaaldrich.com/chemistry/stockroom-reagents/  
learning-center/technical-library/needle-gauge-chart.html](http://www.sigmaaldrich.com/chemistry/stockroom-reagents/learning-center/technical-library/needle-gauge-chart.html)> on Dec.  
1, 2016.\*

\* cited by examiner

*Primary Examiner* — Allison Fox

(74) *Attorney, Agent, or Firm* — David L. King

(57) **ABSTRACT**

The present invention provides a novel way to replenish the  
disc using retooled disc compositions to repair degenerative  
discs. There is no better source of proteoglycans than the  
actual disc material (6) itself. To this end, there has been  
developed a technique to remove the nucleus pulposus and  
retool the morphology of the nucleus pulposus to create a  
powder material (10) that is dry and can be stored at room  
temperature for long periods of time. This powder (10) can  
then be reconstituted with a variety of fluids, the most  
suitable being normal saline or lactated ringers to form a  
flowable mixture (20).

**13 Claims, 3 Drawing Sheets**

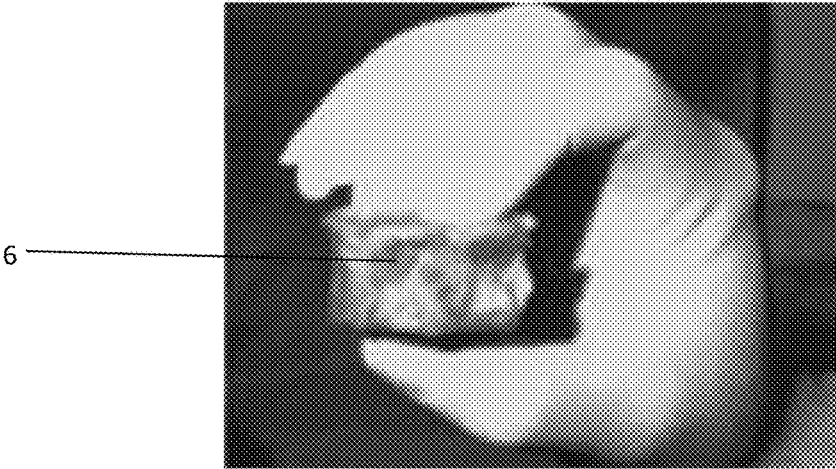

FIG. 1A



FIG. 1B

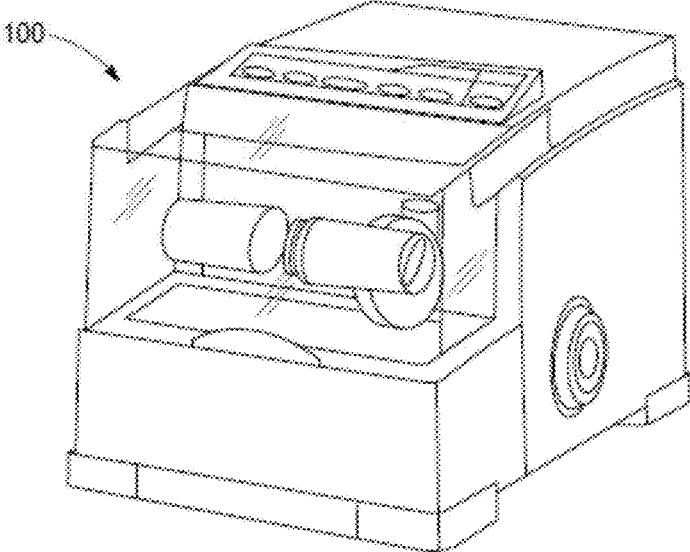

FIG. 2

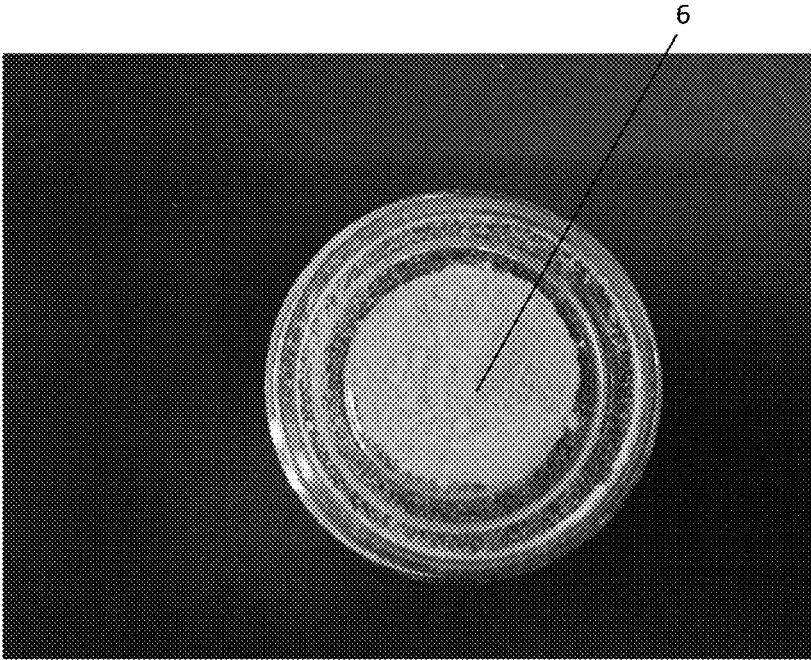

FIG. 3

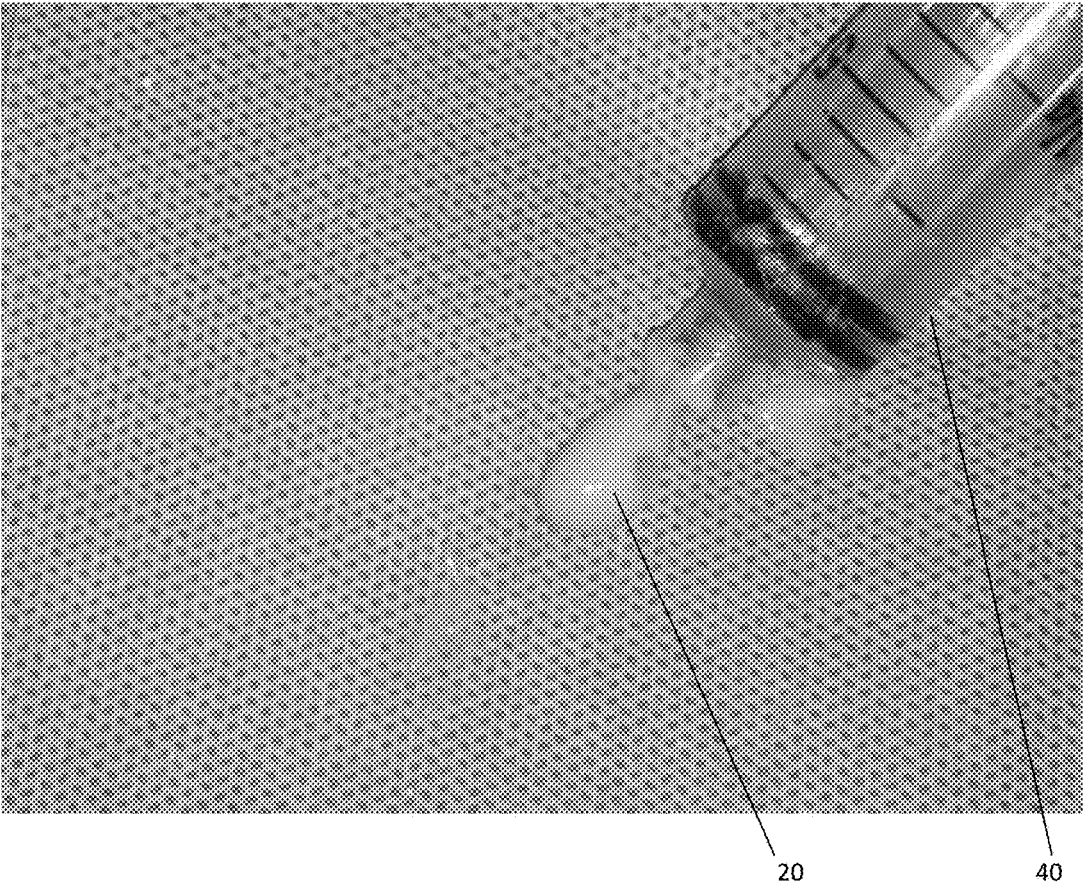

FIG. 4

1

## SPINAL DISC REGENERATIVE COMPOSITION AND METHOD OF MANUFACTURE AND USE

### RELATED APPLICATIONS

The present invention is a division of co-pending U.S. application Ser. No. 14/334,318 filed on Jul. 17, 2014 entitled "Spinal Disc Regenerative Composition And Method Of Manufacture And Use".

### TECHNICAL FIELD

The present invention relates to a spinal disc regenerative composition and method of manufacture and use.

### BACKGROUND OF THE INVENTION

Intervertebral discs are soft and compressible. They are interposed between adjacent vertebral body elements of the spine. They act as shock absorbers for the spine, allowing it to flex, bend, and rotate. Degenerative disc disease can occur throughout the spine, but most often occurs in the discs in the lower back (lumbar region) and the neck (cervical region).

As the process of degeneration continues, micro tears or cracks occur in the outer layer (annulus fibrosus) of the disc. The jellylike material inside the disc (nucleus pulposus) may be forced out through the tears or cracks in the annulus, which causes the disc to bulge, break open (rupture), or break into fragments.

The economic impact of degenerative disc disease is enormous accounting for a significant morbidity and lost wages.

The physical properties of the disc are the nucleus pulposus which is composed of type II collagen and the annulus fibrosus which surrounds the disc and gives it significant form. The annulus composed of type I collagen. The nucleus pulposus is largely made up of molecules called proteoglycans. These proteoglycans have an affinity for water. It is this retention of water and the stoichiometry of folded molecules that is responsible for the unique mechanical properties of the disc. If these proteoglycans are depleted, the discs become more rigid and the loss of fluid results in a disc that is thinner and less compliant. Clinically this results in narrowing of the distances between the vertebral elements. This is best seen on magnetic resonance imaging. Typically discs have a bright signal on T2 pulse-weighted sequences and they are hypointense on corresponding T1 images. This is due to the high fluid content of the discs. As the disc loses fluid i.e. the loss of proteoglycans, the disc loses its water signal and becomes anhydrotic and eventually mineralizes. As a result, these individuals develop the symptoms in the spine contributable to loss of the normal disc architecture. As the process of degeneration continues, one develops micro tears or cracks and fissures in the annulus fibrosis and through these cracks and fissures the nucleus pulposus, which is largely gelatinous, may extrude. The extruded disc material may efface the dura and cause significant nerve compression which may result in traumatic neuritic pain and or motor loss. Therefore, once these early changes in disc degeneration are recognized, it may be prudent to replenish the disc with proteoglycans. Currently, synthetic and artificial substitutes are used to stimulate repair.

### SUMMARY OF THE INVENTION

The present invention provides a novel way to replenish the disc. These novel disc compositions may be used to

2

repair degenerative discs. There is no better source of proteoglycans than the actual disc material itself. To this end, a technique has been developed to remove the nucleus pulposus and retool the morphology of the nucleus pulposus to create a powder material that is dry and can be stored at room temperature for long periods of time. This powder can then be reconstituted with a variety of fluids, the most suitable being normal saline or lactated ringers solution to form a flowable mixture.

The powder could also be mixed with stem cells that are derived from marrow, fat, blood, or any other source, even the interspinous ligaments. It could be combined with micronized amnion, platelet-rich plasma, and a variety of growth factors that can be encapsulated into pharmacologically active microspheres otherwise known as PAMS. The powder could also be combined with genetically altered cells that produce large amounts of glycosaminoglycans, collagen Type 1 or glucose to form the flowable mixture. The micronized material when rehydrated has a high viscosity and allows the rehydrated material to be flowable as injectable through a cannula. This allows the rehydrated material to be stored in a syringe or other injectable device for insertion into a damaged disc to be treated.

This flowable mixture forms a composite composition between the micronized nucleus pulposus that can then be injected using a syringe or any suitable injection delivery device through a very small cannula as small as 2 mm into the disc space. This instrument can be inserted percutaneously into the disc itself during the process of discography. The flowable material of this composite composition is of a sufficiently high viscosity that once hydrated will not necessarily leak out through the injection portal or through pre-existing cracks and fissures in the annulus fibrosus. If however these cracks and fissures are substantial, they could be sealed with fibrin glue as part of the procedure of introducing the composites.

### DEFINITIONS

As used herein and in the claims:

"Cryomill"—The CryoMill is tailored for cryogenic grinding. The grinding jar is continually cooled with liquid nitrogen from the integrated cooling system before and during the grinding process. Thus the sample is embrittled and the chemical composition is preserved. The liquid nitrogen circulates through the system and is continually replenished from an Autofill system in the exact amount which is required to keep the temperature at  $-196^{\circ}$  C. Powerful impact ball milling results in a perfect grinding efficiency. The Autofill system avoids direct contact with LN2 and makes the operation very safe. Its versatility (cryogenic, wet and dry grinding at room temperature) makes the CryoMill the ideal grinder for quantities up to 20 ml. The grinding jar of the CryoMill performs radial oscillations in a horizontal position. The inertia of the grinding balls causes them to impact with high energy on the sample material at the rounded ends of the grinding jar and pulverize it. The grinding jar is continually cooled with liquid nitrogen from the integrated cooling system before and during the grinding process.

"Disc Desiccation"—Disc desiccation is an extremely common degenerative change of intervertebral discs. The incidence climbs with age, and to a large degree a gradual desiccation is a 'normal' part of disc aging. It results from replacement of the hydrophilic glycosaminoglycans within the nucleus pulposus with fibrocartilage.

"Freeze Drying"—Freeze-drying, also known as lyophilization, lyophilization, or cryodesiccation, is a dehydration process typically used to preserve a perishable material or make the material more convenient for transport and stable at room temperatures in an appropriate contained or package. Freeze-drying works by freezing the material and then reducing the surrounding pressure to allow the frozen water in the material to sublime directly from the solid phase to the gas phase.

"Hypothermic Dehydration"—hypothermic dehydration depends on placing the object at reduced temperatures above freezing point into a high vacuum chamber allowing it to dry to a desired residual moisture level. The result is dried tissue without fissures, microscopic ice crystal distortion and collapse phenomenon.

"Nucleus Pulposus"—Nucleus pulposus is the gel-like substance in the middle of the spinal disc. It is the remnant of the notochord. It functions to distribute hydraulic pressure in all directions within each disc under compressive loads. The nucleus pulposus consists of large vacuolated notochord cells, small chondrocyte-like cells, collagen fibrils, and proteoglycan aggregates that aggregate through hyaluronic chains. Attached to each aggregate molecule are the glycosaminoglycan (GAG) chains of chondroitin sulfate and keratan sulfate. Aggrecan is negatively charged, allowing the nucleus pulposus to attract water molecules. The amount of water and glycosaminoglycans decreases with age and degeneration.

"Proteoglycans"—Proteoglycans are proteins that are heavily glycosylated. The basic proteoglycan unit consists of a "core protein" with one or more covalently attached glycosaminoglycan (GAG) chain(s). The point of attachment is a Ser residue to which the glycosaminoglycan is joined through a tetrasaccharide bridge (e.g. chondroitin sulfate-GlcA-Gal-Gal-Xyl-PROTEIN). The Ser residue is generally in the sequence -Ser-Gly-X-Gly- (where X can be any amino acid residue, but Proline), although not every protein with this sequence has an attached glycosaminoglycan. The chains are long, linear carbohydrate polymers that are negatively charged under physiological conditions, due to the occurrence of sulfate and uronic acid groups. Proteoglycans occur in the connective tissue. Proteoglycans are a major component of the animal extracellular matrix, the "filler" substance existing between cells in an organism. Here they form large complexes, both to other proteoglycans, to hyaluronan and to fibrous matrix proteins (such as collagen). They are also involved in binding cations (such as sodium, potassium and calcium) and water, and also regulating the movement of molecules through the matrix. Evidence also shows they can affect the activity and stability of proteins and signaling molecules within the matrix. Individual functions of proteoglycans can be attributed to either the protein core or the attached GAG chain and serve as lubricants.

#### BRIEF DESCRIPTION OF THE DRAWINGS

The invention will be described by way of example and with reference to the accompanying drawings in which:

FIG. 1A is a photo of a spinal segment after being cut from a spine segment.

FIG. 1B is a photo of a vertebral spine segment wherein the adjacent vertebrae are cut, separated and the disc material removed.

FIG. 2 is a photo of an exemplary cryomill.

FIG. 3 is a photo of freeze dried disc material micronized to a fine powder.

FIG. 4 is a photo showing the rehydrated disc material flowing from a syringe.

#### DETAILED DESCRIPTION OF THE INVENTION

The actual disc material **6** is a recovered aseptically, preferably, from human cadaver spine segments **2** from approximately T9 to L5 as shown in FIG. 1A. These are done under sterile conditions. The spinal segments are immediately transferred to a processing room where the disc is isolated by cutting the junction between the end plate and the cancellous bone maintaining intact endplates of the vertebral body **4** above and below so as not to cause extrusion of the disc material as shown in FIG. 1B. The endplates are then removed and the nucleus pulposus is extracted using sharp dissection. The nucleus pulposus is then aggregated from all of the intervertebral discs for that particular case and are placed in a freeze drier and or cold desiccator where the moisture is removed to under 5 percent. The freeze dried material is then placed in aggregate into a cryomill **100** and micronized into a very fine powder **10** as shown in FIG. 2. Preferably, the mill **100** pulverizes the freeze dried nucleus pulposus at low temperatures not exceeding 40° C. to prevent material degradation. The micronized material has particles sized less than 400 microns. This fine powder **10**, as shown in FIGS. 3 and 4, is then placed into a sterile container and can be stored under vacuum seal for long periods of time at room air. Once the fine powder material **10** is selected for administration, it is rehydrated using either normal saline, lactated ringers solution, blood, platelet rich plasma, or a combination of the above. It is then injected into the disc space using a 2-4 mm cannula, the smaller the cannula the better to prevent extrusion of the material out of the disc space following administration. Any pre-existing cracks or fissures are then sealed with fibrin glue after administration of the composite material.

The inventor has developed a biochamber whereby a human disc can be placed in a physiologic environment and loaded biomechanically. Simultaneously, various parameters can be continuously measured such as cellular activity, oxygen tension and glucose depletion.

It is believed a degenerative disc can be recovered and placed in a biological incubator and injected with the rehydrated freeze dried nucleus pulposus powder and incubated over a period of time to demonstrate physiologic repair and healing of the disc by increased metabolic activity, water retention and improved biomechanical strength.

This exemplary test protocol can be used to confirm the efficacy of the various reconstituted rehydrated mixtures proposed herein.

This allows for a unique method of preparing the material composition of proteoglycan containing nucleus pulposus comprising the steps of: Aseptic recovery of cadaveric spine segments **2, 4** from T9 to L5 (FIGS. 1A and 1B); Removal of the discs **6** by cutting between the cancellous bone and vertebral endplate junction; Removing the normal nucleus pulposus; Freeze drying the nucleus pulposus from multiple disc segments; Placing the freeze dried material into a cryomill **100** (FIG. 2); Placing the micronized disc material **10** into a sterile container for later use (FIG. 3).

Additionally, a test procedure may be used to confirm viability of the material which includes the step of: mixing the micronized disc material **10** with saline, stem cells, micronized amnion, platelet rich plasma, growth factors, PAMS (pharmacologically active microspheres), genetically

5

altered cells that produce glycosaminoglycans. This rehydrated mixture **20** can be made a flowable material suitable for delivery from a nozzle type container such as a syringe. Once this micronized powder **10** is rehydrated it can be delivered to treat damaged or degenerative disc repair.

The treatment method can include the steps of: injecting the matrix composite through a 2-4 mm cannula into the disc space (FIG. 4). Smaller apertures through which this material may be injected may be preferable to limit extrusion of the material out of the disc space.

The spinal disc tissue can be prepared by dehydration at hypothermic temperatures.

Optionally, the disc material could be extracted from spine segments of primates or other mammals.

Variations in the present invention are possible in light of the description of it provided herein. While certain representative embodiments and details have been shown for the purpose of illustrating the subject invention, it will be apparent to those skilled in this art that various changes and modifications can be made therein without departing from the scope of the subject invention. It is, therefore, to be understood that changes can be made in the particular embodiments described, which will be within the full intended scope of the invention as defined by the following appended claims.

What is claimed is:

**1.** A composition consisting of:

- (a) a syringe or injectable device which is capable of being inserted into a damaged disc to be treated; and
- (b) a hydrated composition comprising freeze-dried micronized nucleus pulposus in a fluid, produced by a method consisting of:
  - (i) providing normal human cadaveric intervertebral discs;
  - (ii) separating the nucleus pulposus from the annulus fibrosus of the normal human cadaveric intervertebral disc;
  - (iii) drying the nucleus pulposus;
  - (iv) micronizing the dried nucleus pulposus by pulverizing in a cryomill at low temperature into particles sized less than 400 microns;
  - (v) freeze-drying the nucleus pulposus, wherein said freeze-drying occurs during step (iii), between steps (iii) and (iv), and/or after step (iv); and then
  - (vi) mixing the freeze-dried micronized nucleus pulposus with a fluid, thereby producing the hydrated composition;

wherein the (b) hydrated composition is contained within the (a) syringe or injectable device, and wherein the (b) hydrated composition has a viscosity which permits it to flow through a cannula.

**2.** The composition of claim **1** wherein the freeze-dried micronized nucleus pulposus provided for mixing in step (vi) is in the form of a powder.

**3.** The composition of claim **2** wherein the method of production further consists of:

mixing one or more of stem cells that are derived from marrow, fat, blood or interspinous ligaments; micronized amnion; platelet rich plasma; and/or growth factors encapsulated in pharmacologically active microspheres, with the powdered freeze-dried micronized

6

nucleus pulposus prior to step (vi), or with the hydrated composition after step (vi).

**4.** The composition of claim **1** wherein step (i) providing normal human cadaveric intervertebral discs involves aseptically recovering multiple intervertebral disc segments from cadaveric spine segments from T9 to L5 by cutting between cancellous bone and vertebral endplate junctions.

**5.** The composition of claim **1** wherein the fluid used in step (vi) is selected from the group consisting of normal saline, lactated ringers solution, blood, platelet rich plasma, and combinations thereof.

**6.** The composition of claim **1** wherein the (b) hydrated composition has a viscosity that permits the composition to flow through a 22 gauge or finer bore cannula.

**7.** The composition of claim **1** wherein the step (v) freeze-drying of the nucleus pulposus occurs prior to step (iv) micronizing.

**8.** The composition of claim **1** wherein the step (v) freeze-drying of the nucleus pulposus occurs after step (iv) micronizing.

**9.** A composition consisting of:

- (a) a syringe or injectable device which is capable of being inserted into a damaged disc to be treated; and
- (b) a hydrated composition consisting of freeze-dried micronized nucleus pulposus in a fluid, produced by a method consisting of:
  - (i) providing normal human cadaveric intervertebral discs;
  - (ii) separating the nucleus pulposus from the annulus fibrosus of the normal human cadaveric intervertebral discs;
  - (iii) drying the nucleus pulposus;
  - (iv) micronizing the dried nucleus pulposus by placing the dried material in a cryomill at low temperature and pulverizing the dried nucleus pulposus into particles sized less than 400 microns;
  - (v) freeze-drying the nucleus pulposus, wherein said freeze-drying occurs during step (iii), between steps (iii) and (iv), and/or after step (iv); and then
  - (vi) aseptically rehydrating the freeze-dried micronized nucleus pulposus with a fluid, thereby producing the hydrated composition;

wherein the (b) hydrated composition is contained within the (a) syringe or injectable device; and wherein the (b) hydrated composition has a viscosity which permits it to flow through a cannula.

**10.** The composition/product of claim **9** wherein the fluid used in step (vi) rehydrating is selected from the group consisting of normal saline, lactated ringers solution, blood, platelet rich plasma, and combinations thereof.

**11.** The composition of claim **9** wherein the (b) hydrated composition has a viscosity that permits the composition to flow through a 22 gauge or finer bore cannula.

**12.** The composition of claim **9** wherein the step (v) freeze-drying of the nucleus pulposus occurs prior to step (iv) micronizing.

**13.** The composition of claim **9** wherein the step (v) freeze-drying of the nucleus pulposus occurs after step (iv) micronizing.

\* \* \* \* \*